

joloda
hydraroll
LIGHTENING LOADS



rollerbed

modular
systems:
VANS

introduction

Modular Rollerbed Systems

Joloda Hydraroll's range of modular roller systems are a diverse and innovative solution. Our systems are proven to make your logistical processes as easy and dynamic as possible to save you time and money to make your business more efficient and profitable.

Our innovative solutions have seen us specialise in the entire logistical process, from moving cargo around factories, warehouses and airports, to moving loads through docking bays, into vehicles such as trucks and vans.

Our modular roller systems have a variety of different applications. We've assembled a suite of different brochures to help you understand how to streamline your logistics processes and create the ideal solution to your loading problems.



BLOCK PALLETS



AIR CARGO



WAREHOUSES



Our modular rollerbed system is especially designed for handling pallets in vans and small trucks and is a 'floor-on-floor' concept.

The system consists of multiple lightweight aluminium frames that are interconnected and equipped with lanes of rollertrack that feature a pneumatic rise and fall function for handling block pallets.

The average time to install a system and convert a van is between 2-4 working hours for one person, depending on system configuration.

contents

Typical Installations	4	Autodown Function	11
Installation Process	5	Schematic Drawings	12
Basics of Design	6	Installations	13
Rollertrack Types	7	Videos	14
Platform Fixings	8	Why Choose Us?	16
Pneumatic Function	9	About Us	17
Safety Features	10	Global Leaders	19
		Let's Chat	20

typical installations

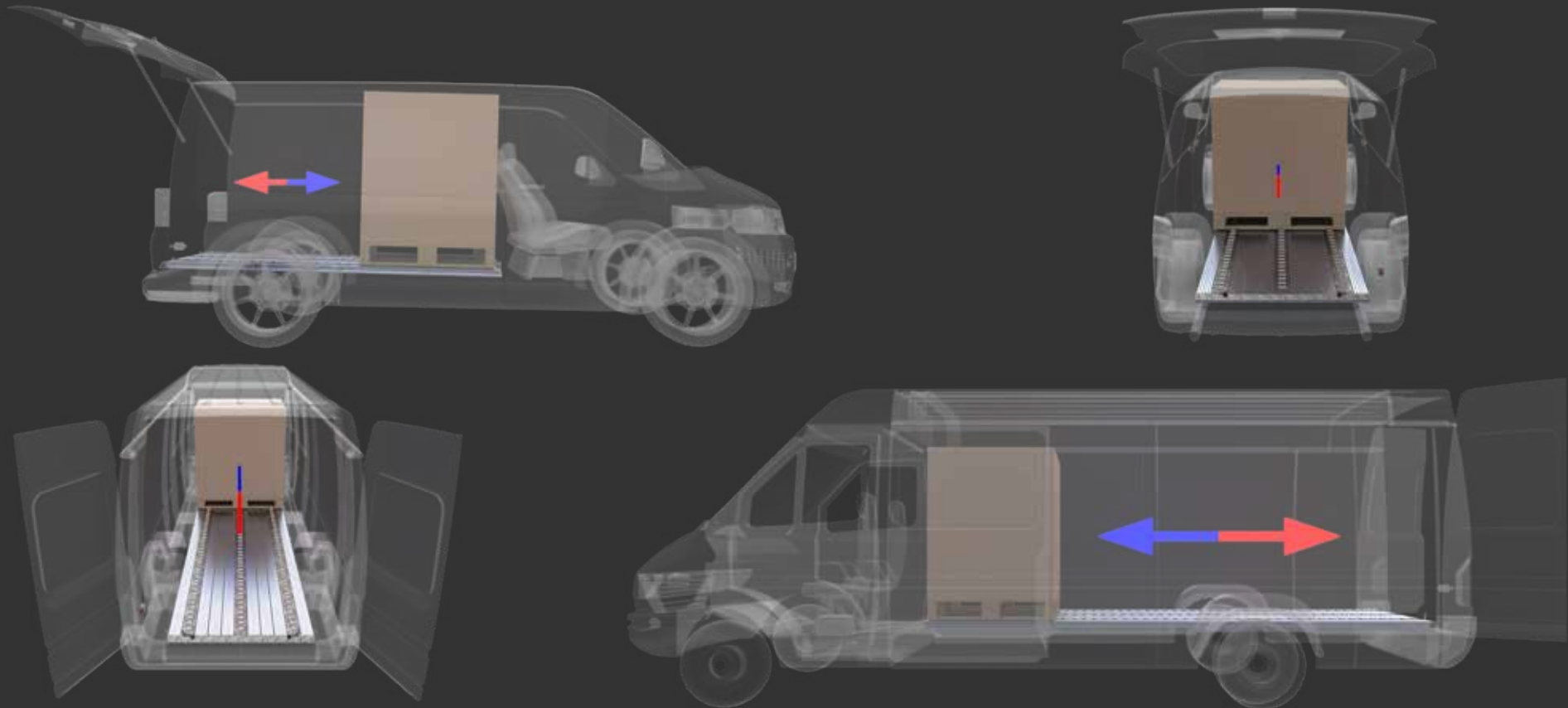

installation 'process'



BEFORE INSTALLATION



READY TO BE INSTALLED



SLIDING IN THE FRAMES



AFTER INSTALLATION

basics of design

Modular Rollerbed System Design

The design of the frames is based on aluminium floorboards, which feature pneumatic rise and fall rollertrack modules. No welding is needed to make a frame.

The frames are supplied partly pre-assembled and ready for installation. Each frame contains 3 lanes of rollertracks. The design of the system is based on a continuous airbag over the full length of the vehicle.

The closing plates on the front sides of the frames are screwed in, whilst the last plate at the door side of the trailer is equipped with two pallet stops. When the pre-mounted frames are in place on the van floor, they are secured using special clamping brackets.

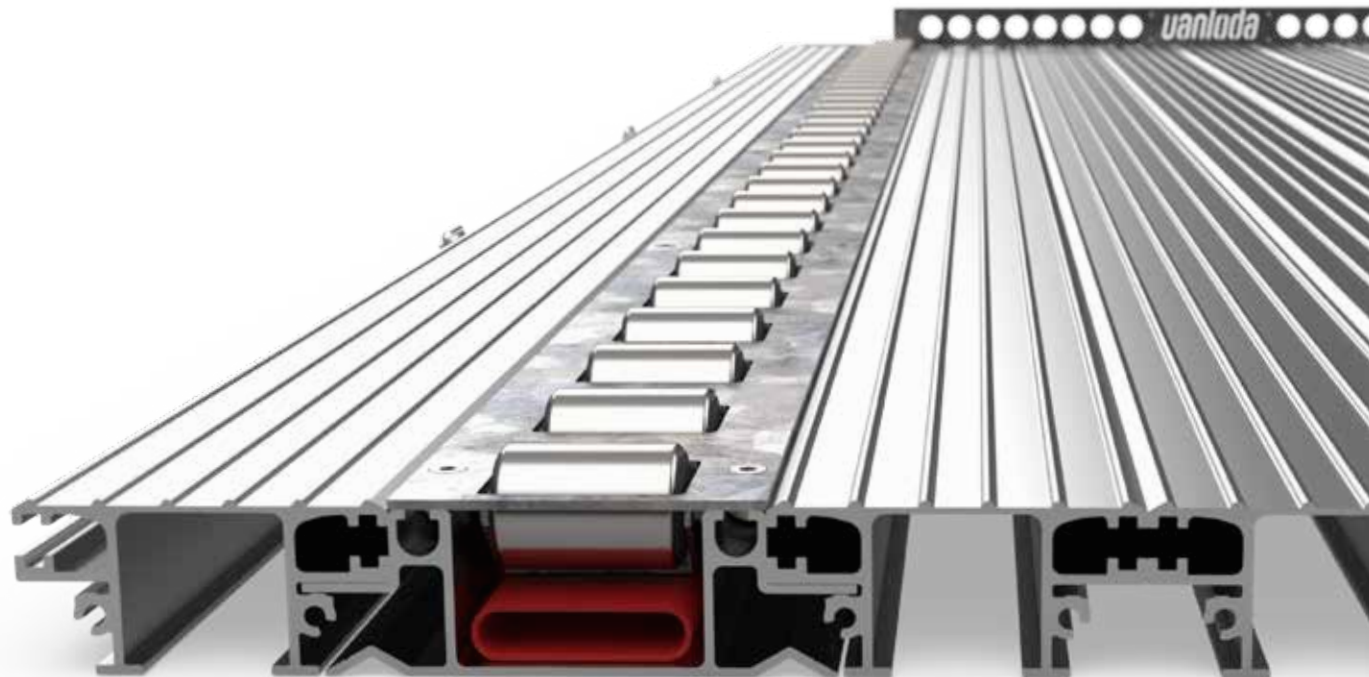

rollertrack types

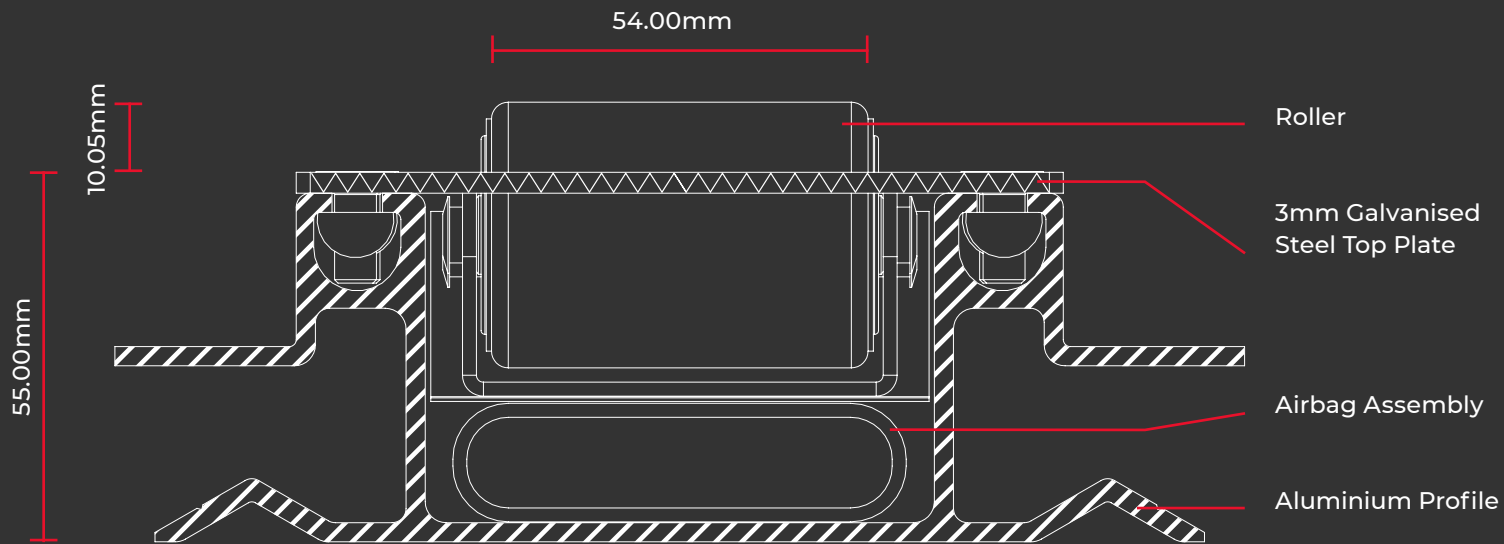

MK9 Single Track Roller
The modular rollerbed system is ideal for safely transporting block pallets and is configured with our MK9-type single rollertrack module (which features a 54mm-wide roller) ensuring that pallets have sufficient support underneath.

platform fixings

Frames and Fixings

The frames can be fixed to the van's floor with galvanized steel clamping brackets or to the van's lashing eyes with a heavy-duty tie-rip.

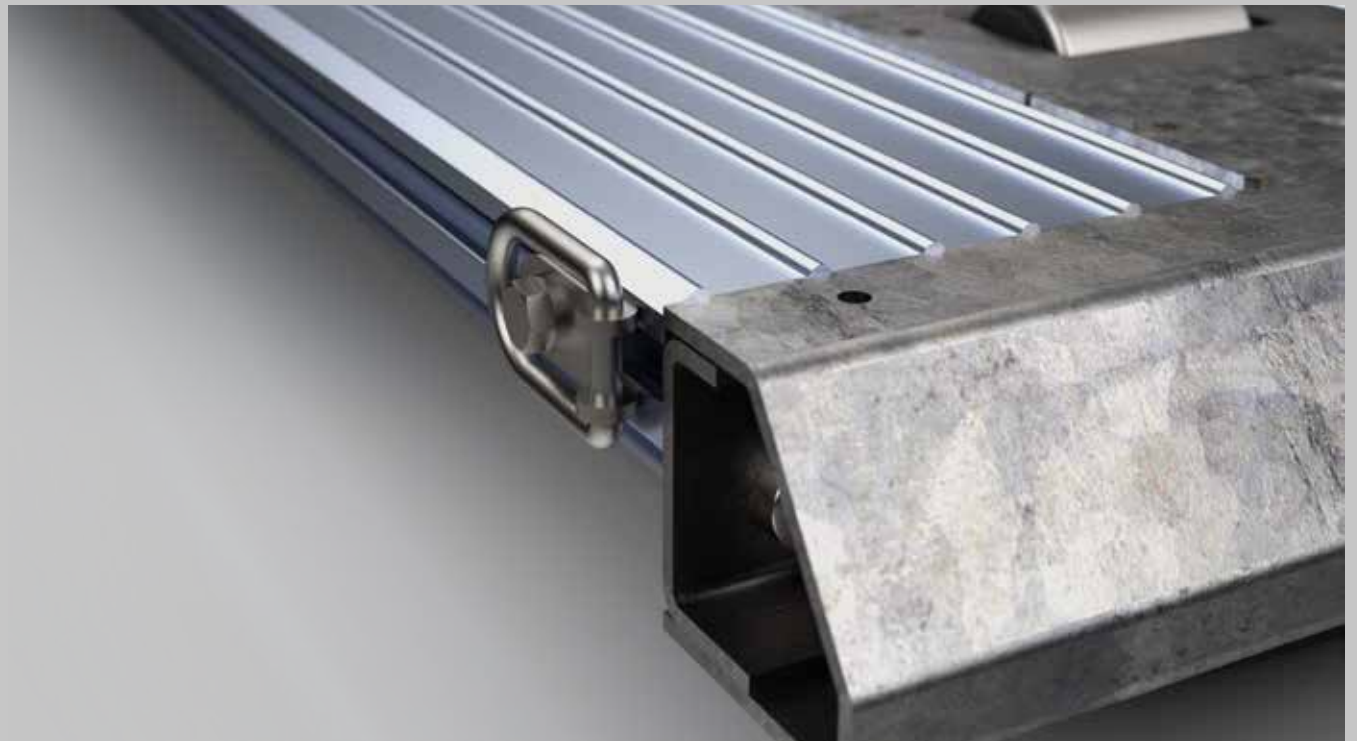

FLOOR FIXING

pneumatic function

The modular rollerbed system rises and falls with the use of a pneumatic function. A compressor unit draws in air into a custom-made plastic box, which features an air inlet, an air outlet and power outlet cable. The box can be positioned in either the cabin or the cargo space.

Since the system doesn't contain an air reservoir tank, the compressor provides air straight to the rollertrack modules. Depending on the length of the rollerbed, each rollertrack module takes about a minute to fully inflate and raise the rollers.



COMPRESSOR UNIT



INSIDE VIEW



INSTALLED UNIT: UNDER
DRIVER'S SEAT



INSTALLED UNIT: IN
BULKHEAD COMPARTMENT

safety features

Bulkhead and Pallet Stops

At the cabin end of the modular rollerbed system, the system features a reinforced galvanized steel kick strip that's 50mm tall. This strip acts as a pallet stop to prevent pallets from hitting the van's bulkhead

Whilst at the other end of the frames (next to the rear doors), the system features a pair of manually-operated flip-up pallet stops. These will prevent the pallets from rolling out.

Pallet Guides

As an option, we can also fit galvanized steel pallet guide profiles on either side of the frames. This will prevent lightweight pallets from sliding side-to-side on the frame whilst in transit.

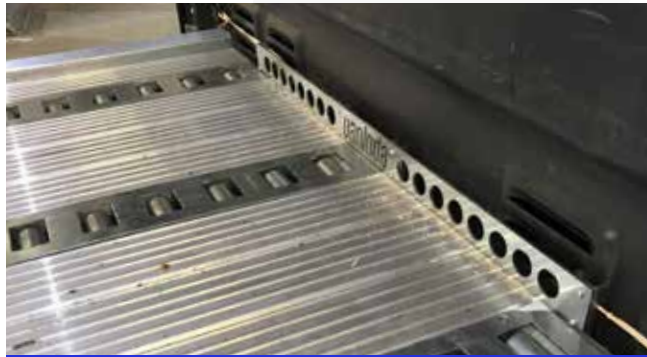

BULKHEAD STOP FEATURE



PALLET GUIDE PROFILE



PALLET STOP & PALLET GUIDE FEATURE



RELEASE 'EXHAUST' BUTTON

autodown function

Safety First

The modular rollerbed system is activated by simply activating an electronic switch. The compressor unit is automatically deactivated when desired pressure is achieved. The switch can be installed anywhere in the vehicle but is typically located at the rear doors.

The system comes complete with an 'Autodown' safety feature; an electronic bypass valve, as standard, which is integrated into the control box.

In the scenario that a frame isn't lowered before the vehicle sets off, the safety feature will lower any raised rollertrack modules to prevent the cargo from being 'live' whilst in transit.

The electronic valve is connected to the vehicle's rear door post, so when the rear doors are closed, it sends an electronic pulse to the control box and activates the exhaust valve, lowering all live sections when the electronic pulse is received.



1. BRAKE PEDAL DEPRESSED

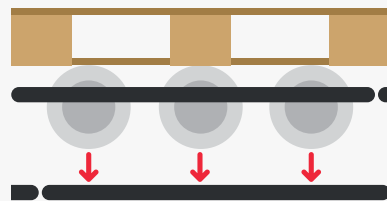

2. RAISED ROLLERTRACK

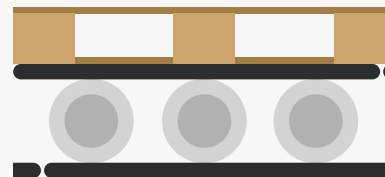

3. SECURE LOAD

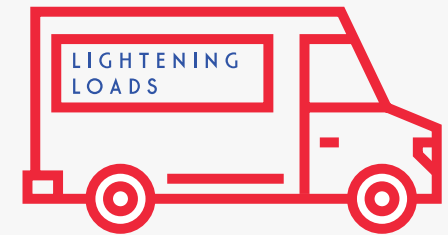

4. SAFE HAULAGE

schematic drawings

Typical layout assembly

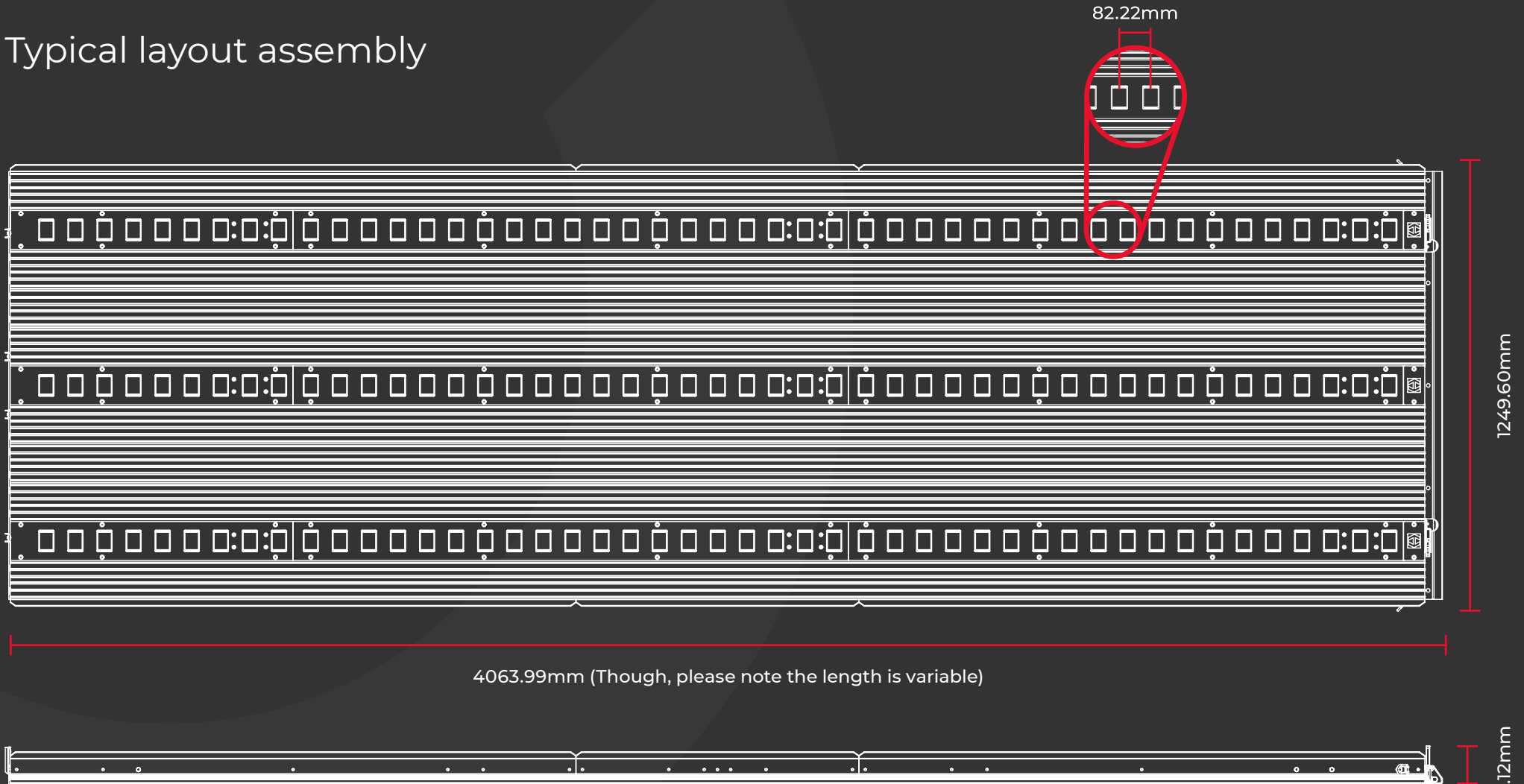





Watch now,
scan here.

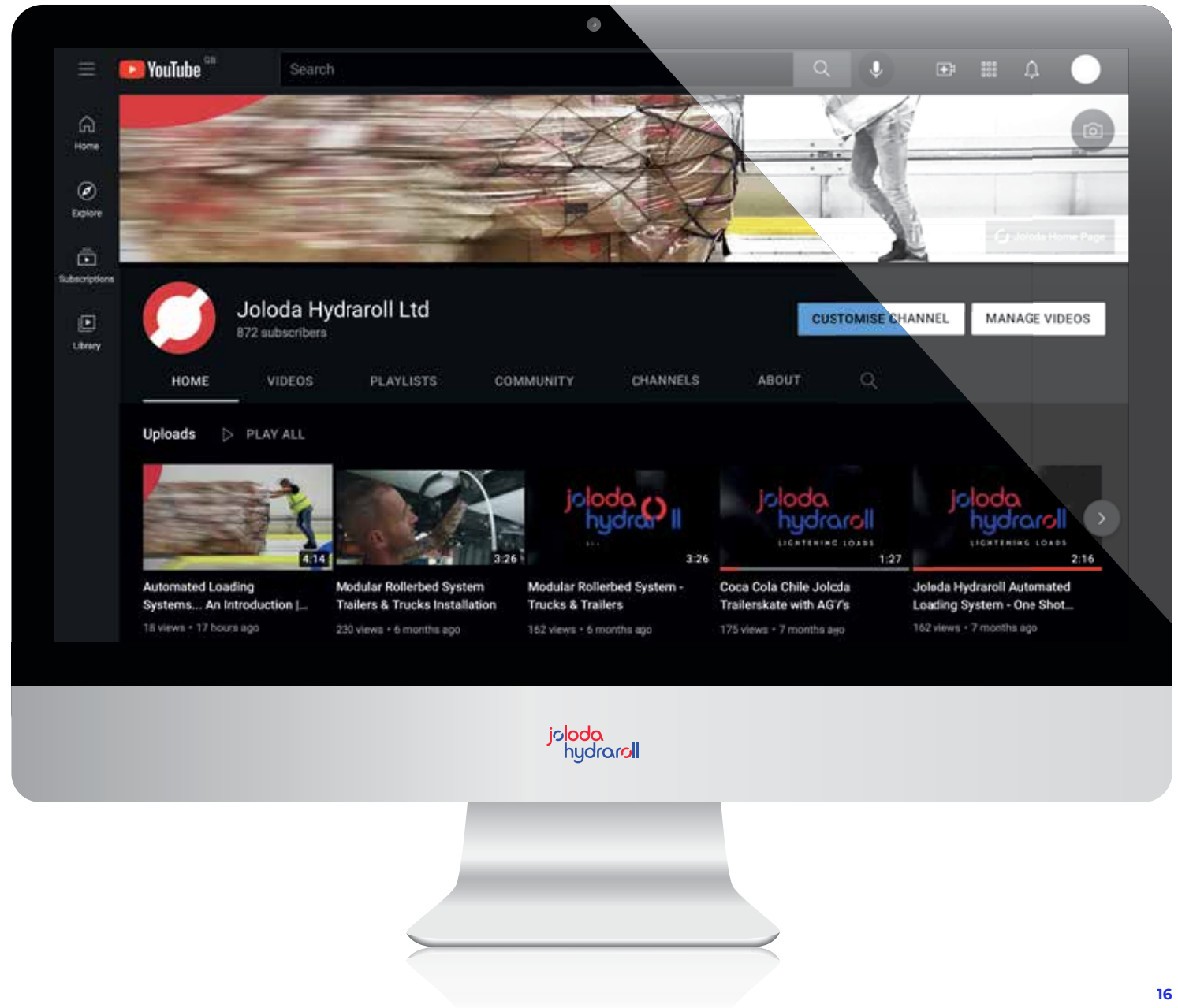

why choose us?

We're much more than 'off-the-shelf'. We're the creators, the experts and we're here to help streamline your logistics and create the ideal loading solutions for your loading problems.



about us

We help businesses lighten loads.
We are highly regarded as the world's leading loading and unloading solutions provider in the logistics industry.

Over the last 60 years, we've helped thousands of businesses streamline their logistics operations to be more cost-efficient, more sustainable, and more health and safety-conscious.

We're more than 'off-the-shelf'. We're the pioneers, the creators, the experts. We design, manufacture, install, service and maintain world-class loading solutions. We can help innovate, automate and streamline your end-of-production line problems, wherever you are.

We have an experienced network of 30+ distributors that offer a helping hand to have experts in local standards.

We have installed more than 500,000 loading systems and through our extensive knowledge and expertise, we inspire change and make manual loading solutions more efficient and effective.

We are the world leaders in loading solutions, and we're here to lighten your load.



a global leader, with local partners



Europe

- Belgium
- Czech Republic
- France
- Germany
- Italy
- Netherlands
- Poland
- Portugal
- Spain
- Sweden
- UK

Asia

- Dubai
- India
- Japan
- Korea
- Malaysia
- Saudi Arabia
- Taiwan
- Thailand
- Turkey

Africa

- Egypt
- South Africa

Americas

- Argentina
- Brazil
- Chile
- Mexico
- USA

Oceania

- Australia

if you have any questions,
please get in touch!

lightening loads around the world

joloda.com

Joloda Hydraroll Ltd (Head Office)

1 De Havilland Drive, Liverpool
L24 8RN, United Kingdom
+44 151 427 8954
hello@joloda.com

Joloda Loading Automation (USA Office)

PO Box 4820, Wilmington
North Carolina, 28406, USA
+1 910 791 2125
brett.murrill@loading-automation.com

Joloda BV (European Office)

De Hulst 13, 5807 EW, Oostrum
Venray, The Netherlands
+31 478 501 059
sales@joloda.nl

Joloda Hydraroll SAS (French Office)

1 Cour du Havre, CS50101
75008 Paris, France
+ 33 7 81 41 99 00
jbalsemin@joloda.com